

# SLG1430

## Liquid Mass Flow Meter

- Resolution down to 500 pL/min
- High pressure resistance, totally media isolated
- Flow path made of fused silica and PEEK™ only
- Minimized swept volume
- Outstanding repeatability of all measurements
- Calibrated, linear output
- RS-232 digital interface



June 2009 V1.6

## SLG1430 Product Summary

The SLG1430 Liquid Flow Meter enables extremely sensitive and fast measurements of ultra low liquid mass flows. This particularly small and light device operates with high pressure resistant total media isolation and hardly any dead volume. The unique performance of this Swiss made device is based on Sensirion's unsurpassed CMOSens® sensor technology which combines a high precision sensor element with the amplification and A/D converter circuit and digital signal processing on one single CMOS chip. This results in superior resolution, fast response time and large dynamic range at lowest power consumption.

Excellent chemical resistance and bio-compatibility is ensured. The medium only gets in contact with the internal fused silica capillary and PEEK™ screw fittings. This sensor is made for microfluidic systems. Typical applications include precise liquid flow measurement and metering for liquid chromatography, lab-on-a-chip systems, drug delivery, life sciences and quality testing. The SLG1430 withstands fluid overpressures of 150-350 bar (2900 psi) during operation.

The sensor requires a supply voltage of 7...18 V<sub>DC</sub> and provides an RS-232 compliant digital interface for communication.

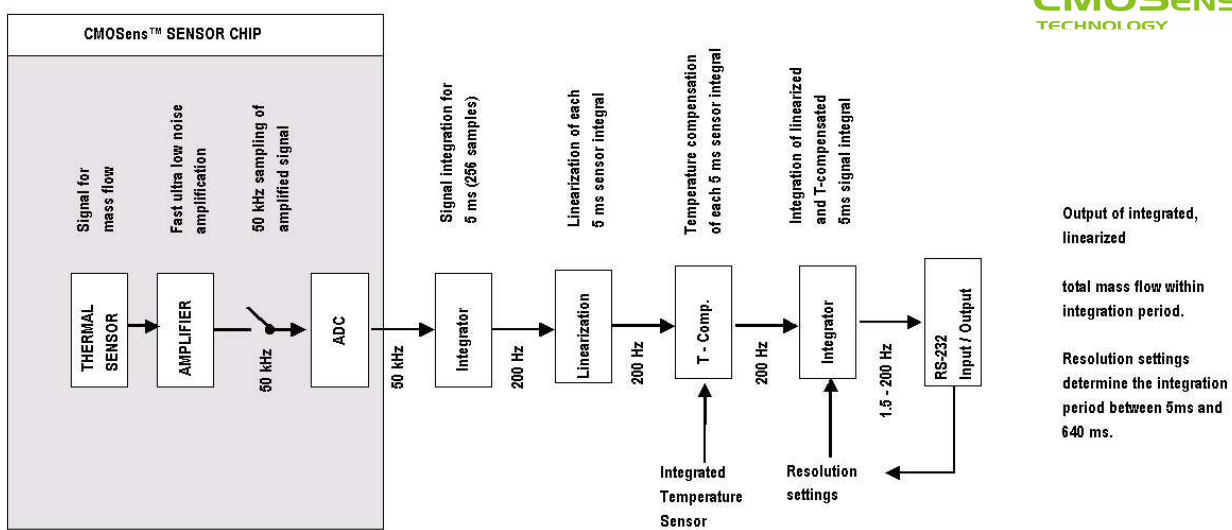

Figure 1: Block Diagram SLG1430 Liquid Flow Meter.

## Introductory Description

The heart of the Swiss made SLG1430 Liquid Flow Meter is powered by Sensirion's unsurpassed CMOSens® sensor technology. The SLG1430 Liquid Flow Meter therefore provides unbeatable performance at very attractive system cost. The different types of this sensor cover a measurement range up to 40 µl/min (H<sub>2</sub>O) with a lowest detectable flow far below 0.5 nl/min. Achieving this measurement with an ultra fast response time, the SLG1430 continues to set a new standards wherever liquid mass flow in the nano- to micro liter range has to be measured or controlled.

The SLG1430 Liquid Flow Sensor runs with an internal flow integration time of 5 ms, allowing correct measurement and display of fast changing flows. However, very often, a precise total flow over a longer period is of greater interest than a single fast measurement. For this purpose the SLG1430 can be set to slower read out times (see Table 4). The sensor internally still integrates flow in 5 ms slices and recognizes fast signal changes but as far as the read out is concerned, the total flow over the whole period is calculated. The SLG1430 device measures true liquid mass flow. You simply connect the system with the liquid flow to be measured to the SLG1430 device to get an instantaneous liquid flow integral with a selectable integration time between 5 ms and 640 ms. The specified flow range can be directly measured by connecting the SLG1430. Very high repeatability, a main goal for most processes, is ensured even for ultra low flows and different types of media.

In addition to the flow signal, the SLG1430 device provides information about the temperature on the CMOSens® sensor element. Both liquid flow and temperature data are accessed through an RS-232 interface. The RS-232 interface allows you to directly connect the SLG1430 device to a PC or PDA using standard viewer software or special solutions. In general, all liquids which are compatible with fused silica and PEEK™, can be used with the SLG1430. However, the standard calibration medium is water.

To get started quickly working in laboratory, a LabKit including one SLG1430 device, PC software, cables, fitting components and power supply (plug & play) is available from Sensirion AG.

## CMOSens® Technology

CMOSens® is the base technology for all Sensirion multi sensor modules and sensor systems. The unification of digital semiconductor chip and sensor

technology serves as a platform for highly integrated system solutions with excellent sensor precision and reliability. With CMOSens®, the on-chip sensor element forms an integrated whole with a high-end amplification and A/D converter circuit. Due to the compact single-chip design, CMOSens® based sensors are very resistant to electromagnetic disturbances (EMC), another important technical advantage of this high end sensor technology. As a result, CMOSens® based sensor modules offer excellent sensor precision, fast response time and a very large dynamic measurement range. In addition, the digital intelligence of the CMOSens® sensor technology enables digital interfaces that permit an easy link with the system of the customer, a real advantage and benefit that results in ready-to-use problem solutions.

CMOSens® liquid mass flow sensors are formed by mounting the highly sensitive microchip on the outside of a straight fused silica capillary. Sophisticated packaging enables the system to measure precisely the liquid flow in the capillary through the tubing material while guaranteeing a total media isolation.

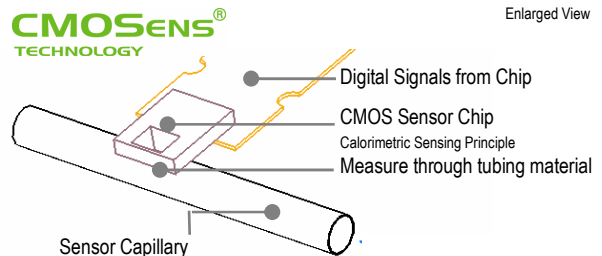

Figure 2: Patent Pending Principle of Media Isolated and Pressure Resistant Flow Sensing  
**(US Patent 6,813,944 B2)**

## 1 Liquid Mass Flow Sensor Performance

Table 1: SLG1430 Models<sup>h</sup> & Flow Ranges

Model	Capillary ID	Maximum Flow <sup>c</sup>	Typ. Resolution <sup>c</sup>	Calibrated Flow Range (reference medium, bidirectional)	
				calib. min flow	calib. max flow
SLG1430-025	25 µm	1.5 µl/min	0.5 nl/min	50 nl/min	1500 nl/min
SLG1430-150	150 µm	7.0 µl/min	1.5 nl/min	250 nl/min	7000 nl/min
SLG1430-480	480 µm	40.0 µl/min	7.0 nl/min	1.0 µl/min	40.0 µl/min

Table 2: SLG1430 Flow Sensing Performance<sup>h</sup> (all data for 23°C, 1 bar<sub>abs</sub> unless otherwise noted).

Parameter	Condition	SLG1430			Units
		-025	-150	-480	
Resolution <sup>a,d</sup>	flow = calib. max flow	0.45	0.3	0.3	% of measured value
	flow = calib. min flow	0.90	0.3	0.3	% of measured value
	flow ≤ calib. min flow	0.45	1.5	6.0	nl/min
Maximum Pressure Drop	flow = calib. max flow	1.5	0.05	0.02	bar <sup>b</sup>
Repeatability <sup>c</sup>	flow ≥ calib. min flow <sup>c</sup>	0.9	0.6	0.6	% of measured value
Accuracy <sup>c</sup>	flow ≥ calib. min flow <sup>c</sup>	10 <sup>d</sup>	10 <sup>d</sup>	10 <sup>d</sup>	% of measured value
Mounting Orientation Sensitivity <sup>e</sup>		< 1.0	< 1.5	tbd	% of measured value

Table 3: SLG1430 Pressure, Speed and Temperature Specifications

Parameter	Condition	Minimum <sup>h</sup>	Typical <sup>h</sup>	Maximum <sup>h</sup>	Units
Overpressure Resistance <sup>f</sup>					
SLG1430-025 / -150	Tested at 400 bar		350		bar <sup>b</sup>
SLG1430-480 <sup>h</sup>	Tested at 200 bar		150		bar <sup>b</sup>
Overpressure related Offset			<0.005		% m.v. / bar
Digital Response Time <sup>a</sup> (Data Readout)		5		640	ms
Flow Detection Response Time <sup>i</sup>			20	80	ms
Operating Temperature (for best performance)		+10	+23	+45	°C
Temperature Coefficient		0.001	0.05	< 0.15	% FS / K
<b>Temperature Sensor</b>	Measures temperature inside the sensor chip, but not of the surrounding air <sup>g</sup>				
Dynamic Range		+10		40	°C
Resolution			0.1		°C
Accuracy		3	2		°C

<sup>a</sup> See Table 4<sup>b</sup> 1 bar = 100 000 Pa = 0.9869 atm = 401.9 inch H<sub>2</sub>O = 14.5 psi; Continuous pressure changes may weaken the fittings!<sup>c</sup> Reference conditions: 1 bar<sub>abs</sub>, const. 23°C, offset 0, medium H<sub>2</sub>O, vertical mounting position (electrical connector up)<sup>d</sup> Better available on request. Allow the Sensor to warm up for best results.<sup>e</sup> For low flow measurements with high accuracy vertical mounting position (connector up) is recommended<sup>f</sup> Overpressure in operation; High overpressure resistance for OEM-solutions. (up to 400 bar) on request<sup>g</sup> The chip warms up by about 4K (depending on supply voltage and ventilation)<sup>h</sup> All technical data is **preliminary** for SLG1430-480<sup>i</sup> Based on numerical simulations

Table 4: Change of Resolution at Different Integration Times (reference conditions)

Sensor Resolution	Readout Frequency 200 Hz	Readout Frequency 50 Hz	Readout Frequency 12.5 Hz	Readout Frequency 1.56 Hz
<b>Best Resolution to be multiplied by ...</b>	64	16	4	1
<b>Mass Flow Integration Time</b>	5 ms	20 ms	80 ms	640 ms

### 1.1 Sensor Principle and Media Types

The SLG1430 device detects liquid mass flow by measuring heat transfer through the tubing material of a standard fused silica capillary. On a microchip outside the capillary, a heating resistor on a thermally optimized membrane is kept above ambient temperature. In the presence of liquid flow inside the capillary, the temperature distribution up- and downstream is disturbed. This asymmetry is then measured by two temperature sensors. Due to the minimal thermal mass of the system, symmetrical arrangement, and accurate temperature measurement, the revolutionary specifications of the SLG1430 devices are achieved while providing total media isolation and pressure resistance.

The above-mentioned thermal principle depends on the type of liquid used. The SLG1430 is calibrated for water. Nevertheless the sensor guarantees an outstanding repeatability for a wide range of different media though offset, sensitivity and measurement range may change. It is recommended to characterize the sensor output separately when starting to perform such measurements. Units calibrated directly for other liquid types are available on request.

### 1.2 Calibrated Data Mode

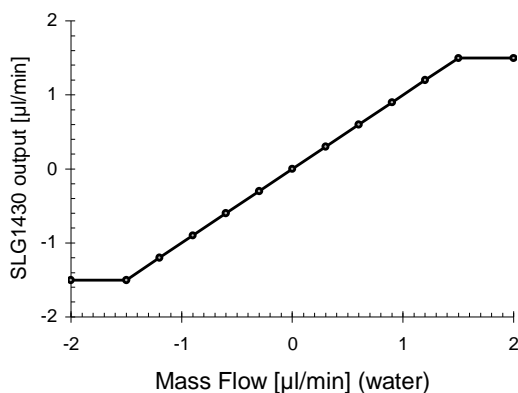

Figure 3: SLG1430-025 transfer characteristics in calibrated data mode.

Figure 3 shows the applied liquid flow vs. the digital output of the SLG1430-025 for H<sub>2</sub>O in calibrated data mode. Beyond the limits of the output, the signal remains constant.

### 1.3 Raw Data Mode

For applications where high repeatability is most important and different types of media are used, the sensor can be switched to raw data mode. By doing this non-linear effects can be monitored without influence of the internal calibration data.

Figure 4 shows the applied liquid flow vs. the digital output of the SLG1430 in raw data mode.

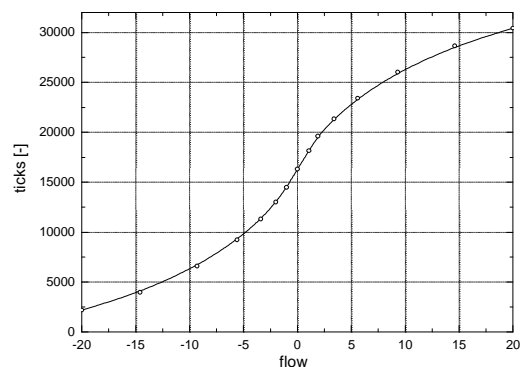

Figure 4: Qualitative transfer characteristics of SLG1430 in raw data mode.

## 2 Digital Interface and Power Supply

For communication and power supply the SLG1430 is equipped with an M8 connector IEC 60947-5-2 (e.g. Hirschmann E Series M8). (Blank cables for this connector are available at Sensirion. Refer to article number 1-100136-01)

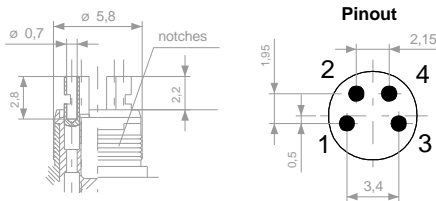

Figure 5: Connector for RS232 and power supply with pinout view from outside

Pin	Description
1	VDD
2	TxD (Sensor Transmitting Data)
3	RxD (Sensor Receiving Data)
4	GND (Ground)

### GND and VDD (Power Supply)

The SLG1430 requires a voltage supply of between 7V and 18 V. Since this voltage is internally regulated, there are no stringent requirements as far as ripple and stability are concerned.

### 2.1 Digital Interface Dataformat

The SLG1430 has a bi-directional RS-232 interface to set configuration and to get flow or temperature values. The received value is a 16 bit integer in the two's complement representation.

received value (hex)	received value (dec)	flow [µl/min]	temperature [°C]
0x7EFF	32511	+1548.140	+320.00*
⋮	⋮	⋮	⋮
0x0001	1	+0.0476	0.01
0x0000	0	0.0000	0.00
0xFFFF	-1	-0.0476	-0.01
⋮	⋮	⋮	⋮
0x8101	-32511	-1548.140	-320.00*

\*not possible value, just to show the principle

Table 5: Interpretation of integer values

The calibrated data is multiplied by a constant factor <sup>a</sup> and then rounded to the next smaller integer in order to transfer also fractions of a unit through the integer

protocol. Example: with factor<sup>a</sup>=21 a received value of +1234 (dec) corresponds either to 58.76 µl/min in flow mode or 12.34 °C in temperature mode<sup>a</sup>.

### RS-232 Interface

All configurations (see also Section 3) for the SLG1430 can be set using its RS-232 interface. The following pins are required to communicate with the SLG1430 via RS-232:

- RxD (Receiving Data Line)
- TxD (Transmitting Data Line)
- GND (Ground)

The RS-232 protocol of the SLG1430 is configured as follows:

Baud Rate	19200
Data Bits	8
Stop Bits	1
Parity	none
Protocol	none
Echo	the sensor generates an echo

With these settings, the SLG1430 device can be connected to any PC or device with an RS-232. The commands have to be sent in ASCII format, the measurement values are provided as a 16 bit integer in binary format with 2 bytes synchronization preceding.

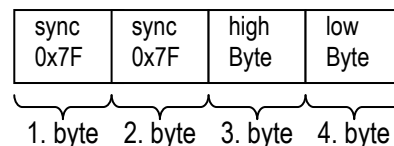

Figure 6: Byte sequence of one value

Because of the maximum range of 0x7EFF, the high byte will never contain 0x7F. So, the worst case is, if the lower byte contains 0x7F. In this special case, 0x7F appears three times in a row.

Example (val=7C 7F):

received string: 7F 7F 7C 7F 7F 7F 7C 7F  
 right sync: 7F 7F 7C 7F 7F 7F 7C 7F  
 wrong sync: 7F 7F 7F 7C

The best approach to find the sync in pseudo code:  
 if (buffer[ i ]=7F and buffer[ i+1]=7F and buffer[ i+2] <> 7F)  
 then buffer[ i ] and buffer[ i+1 ] are sync bytes.

<sup>a</sup> Always use 'info' command to determine individual values of your sensor

### 3 Configuration and Commands

The SLG1430 device accepts a set of commands through its RS-232 interface (see Table 7 for valid commands; for correct settings of the RS-232 refer to Section 2.1). This allows the user to configure the SLG1430 device. Since the configuration is stored in the internal EEPROM, it is maintained after power interruptions.

With the exception of the stop **s** command, all commands have to be sent in the ASCII-format and terminated by the return key ( $\downarrow$ , ASCII #10 or #13; never #10 and #13). After completion of a command, the SLG1430 returns **ok** and is ready to accept a new instruction<sup>a</sup>. Before entering a command, it might be necessary to clear the buffer by means of using  $\downarrow$ . There is a trade-off between resolution and measurement time. Possible settings are listed in Table 6. Choosing 12 bit results for example in a

measurement interval of 80 ms. With the max resolution of 15 bit, a new measurement is provided every 640 ms.

Table 6: Resolution settings using the **res=value** command and corresponding response times

res=	Resolution [bit]	Internal signal integration time [ms]	Data rate [Hz]
0	8	5	200
1	9	10	100
2	10	20	50
3	11	40	25
4	12	80	12.5
5	13	160	6.25
6	14	320	3.125
7	15	640	1.56

Table 7: RS-232 Interface Commands

Command	Output	Description
help $\downarrow$	commands	Lists all available commands. More commands available with security mode off.
ver $\downarrow$	version	Provides type of sensor, firmware version and article number
info $\downarrow$	calibration	Unit / Factor Flow / Overflow / Sensitivity / Factor Temperature
data $\downarrow$	serial ID	Sensor serial number
go $\downarrow$		Starts series of measurements
S	stop	Stops series of measurements
get $\downarrow$		Start single measurement (lifetime limitation: 1 Mio cycles)
mod=F   T $\downarrow$ <sup>a</sup>	mode	Selects flow- (F) or temperature mode (T), (mod? = Status)
res=0..7 $\downarrow$ <sup>a</sup>	resolution	Sets resolution: 0 -> 8 bits; 7 -> 15 bits, see Table 6, (res? = Status)
rdatax $\downarrow$		Reads 4 user defined bytes at the address x={0,...,9}
wdatax=yyyy $\downarrow$		Writes a maximum of 4 user defined bytes at the address x={0,...,9}
test $\downarrow$		Sensor selftest
reset $\downarrow$		Resets SLG1430 device
pw=expand		Switch security mode off. Allows selecting raw data mode.
raw= 1   0		Selects data mode: 1=raw data, 0 = linearized

#### Notes:

- The commands are not case sensitive.
- In order to send a new command to the SLG1430, make sure the SLG1430 is not in measurement mode. Issue therefore a stop command **s** first. After this, any instruction can be given to the SLG1430 and a new series of measurements can be started by **go $\downarrow$** .
- Due to the limited write cycles allowed (lifetime limitation: 1 Mio cycles) for the EEPROM, excessive configuration modifications should be avoided. Even the get-command underlies this limitation.

<sup>a</sup> The commands mod? and res? do not return ok



**RS232 Communication Error Codes**

ERROR 01	Invalid command
ERROR 02	Wrong syntax
ERROR 03	Value out of range
ERROR 04	Not allowed mode
ERROR 50	Invalid EEPROM
ERROR 99	Internal error

**4 Electrical and Mechanical Specifications SLG1430**

**4.1 Absolute Maximum Ratings**

Ambient storage temperature	-10°C to 60°C	(with no liquid inside!)
Ambient operating temperature	10°C to 45°C	
Overpressure resistance	400 bar tested	

**4.2 Mechanical Specifications**

Table 8: Mechanical Specifications<sup>h</sup>

Parameter	Conditions	Min.	Typ.	Max.	Units
Fluid Connectors	PEEK™ Micro Fitting for 360 μm Capillaries				
Connected Fluid Capillary, Outer Diameter	PEEK™ or Fused Silica		360		μm
Internal Sensor Capillary, Inner Diameter		See Table 1			
Total Internal Volume	SLG1430-025			150	nl
	SLG1430-150			1	μl
	SLG1430-480 <sup>h</sup>			10.3	μl
Total Mass			33		g

Remark
In order to avoid irreversible <b>clogging</b> of the sensor the additional usage of an appropriate inline filter is highly recommended especially for the SLG1430-025.



**Attention: Never remove sensor port!**

Sensor port is part of the sensor and should never be unscrewed. Disassembling the sensor will

- void the warranty,
- void the sensor calibration and
- cause (unreparable) leakage.

(No special care necessary: removing port of the sensor takes considerable force and cannot happen accidentally.)

Sensor port is part of sensor; never remove!

Unscrew for connecting tubing

### 4.3 Electrical Specifications

Table 9: SLG1430 DC Characteristics.

Parameter	Conditions	Min.	Typ.	Max.	Units
Power Supply DC	DC abs. maximum rating	7	9	18	V
Operating Current	VDD = 9 V, no load		20		mA
	VDD = 9 V, 3kΩ at RS232 output		27		mA
Power Dissipation	VDD = 9 V, no load		180		mW

Table 10: SLG1430 RS-232 Characteristics.

Parameter	Conditions	Min.	Typ.	Max.	Units
<b>RS232 Output</b>					
Output Voltage Swing	Transmitter output loaded with 3kΩ	±5	±9		V
Power-Off Output Resistance		300			Ω
Output Short Circuit Current			±18		mA
<b>RS-232 Input</b>					
Voltage Range	abs. maximum rating	-15		15	V
Voltage Threshold					
Low		0.8	1.2		V
High			1.7	2.4	V
Hysteresis		0.2	0.5	1.0	V
Resistance		3	5	7	kΩ

### 5 Physical Dimensions

The SLG1430 is mounted in a rugged, weather proofed and chemically inert PBT housing. Physical dimensions are provided in Figure 7.

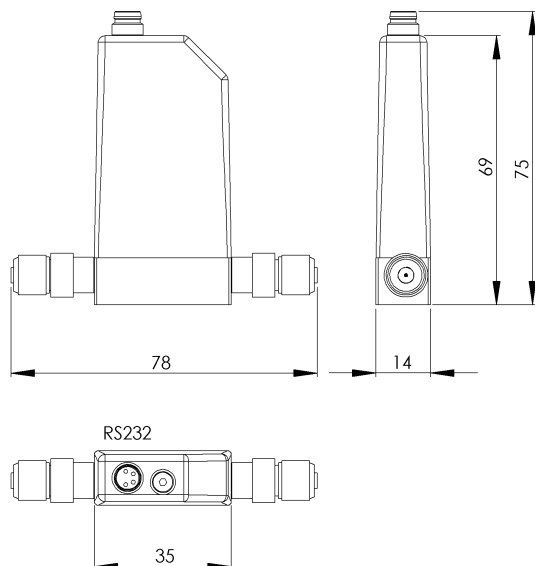

Figure 7: Physical Dimensions of the SLG1430

### 6 Ordering Information

For laboratory use and technology evaluation, the LabKit SLG1430 can be ordered. This laboratory-package contains

- Liquid Flow Sensor SLG1430-xxx
- PC Software (Viewer & Data Export Tool)
- 2 μm Inline Filter for SLG1430-025
- OD360 PEEK Capillaries
- Data Cable RS232
- A/C Adaptor (110...230 V, 50..60Hz)

For OEM applications the sensor can be purchased in larger quantities without any additional parts.

Please specify the SLG1430 type needed.

Product	Article Number
LabKit SLG1430-025	1-100122-01
LabKit SLG1430-150	1-100121-01
LabKit SLG1430-480	1-100247-01
SLG1430-025	1-100119-01
SLG1430-150	1-100118-01
SLG1430-480	1-100246-01



## 7 Important Notices

### 7.1 Warning, personal injury

**Do not use this product as safety or emergency stop devices or in any other application where failure of the product could result in personal injury. Do not use this product for applications other than its intended and authorized use. Before installing, handling, using or servicing this product, please consult the data sheet and application notes. Failure to comply with these instructions could result in death or serious injury.**

If the Buyer shall purchase or use SENSIRION products for any unintended or unauthorized application, Buyer shall defend, indemnify and hold harmless SENSIRION and its officers, employees, subsidiaries, affiliates and distributors against all claims, costs, damages and expenses, and reasonable attorney fees arising out of, directly or indirectly, any claim of personal injury or death associated with such unintended or unauthorized use, even if SENSIRION shall be allegedly negligent with respect to the design or the manufacture of the product.

### 7.2 ESD Precautions

The inherent design of this component causes it to be sensitive to electrostatic discharge (ESD). To prevent ESD-induced damage and/or degradation, take customary and statutory ESD precautions when handling this product.

See application note "ESD, Latchup and EMC" for more information.

### 7.3 Warranty

SENSIRION warrants solely to the original purchaser of this product for a period of 12 months (one year) from the date of delivery that this product shall be of the quality, material and workmanship defined in SENSIRION's published specifications of the product. Within such period, if proven to be defective, SENSIRION shall repair and/or replace this product, in SENSIRION's discretion, free of charge to the Buyer, provided that:

- notice in writing describing the defects shall be given to SENSIRION within fourteen (14) days after their appearance;
- such defects shall be found, to SENSIRION's reasonable satisfaction, to have arisen from SENSIRION's faulty design, material, or workmanship;
- the defective product shall be returned to SENSIRION's factory at the Buyer's expense; and
- the warranty period for any repaired or replaced product shall be limited to the unexpired portion of the original period.

This warranty does not apply to any equipment which has not been installed and used within the specifications recommended by SENSIRION for the intended and proper use of the equipment. EXCEPT FOR THE WARRANTIES EXPRESSLY SET FORTH HEREIN, SENSIRION MAKES NO WARRANTIES, EITHER EXPRESS OR IMPLIED, WITH RESPECT TO THE PRODUCT. ANY AND ALL WARRANTIES, INCLUDING WITHOUT LIMITATION, WARRANTIES OF MERCHANTABILITY OR FITNESS FOR A PARTICULAR PURPOSE, ARE EXPRESSLY EXCLUDED AND DECLINED.

SENSIRION is only liable for defects of this product arising under the conditions of operation provided for in the data sheet and proper use of the goods. SENSIRION explicitly disclaims all warranties, express or implied, for any period during which the goods are operated or stored not in accordance with the technical specifications.

SENSIRION does not assume any liability arising out of any application or use of any product or circuit and specifically disclaims any and all liability, including without limitation consequential or incidental damages. All operating parameters, including without limitation recommended parameters, must be validated for each customer's applications by

customer's technical experts. Recommended parameters can and do vary in different applications.

SENSIRION reserves the right, without further notice, (i) to change the product specifications and/or the information in this document and (ii) to improve reliability, functions and design of this product.

Copyright© 2001-2009, SENSIRION.  
 CMOSens® is a trademark of Sensirion  
 All rights reserved.

PEEK™ is a trademark of Victrex PLC

### FCC and CE Statement

This product has been tested and found to comply with the limits for a Class B digital device, pursuant to part 15 of the FCC Rules (FCC CFR 47). These limits are designed to provide reasonable protection against harmful interference in a residential installation. This equipment generates, uses and can radiate radio frequency energy and, if not installed and used in accordance with the instructions, may cause harmful interference to radio communications. However, there is no guarantee that interference will not occur in a particular installation. If this equipment does cause harmful interference to radio or television reception, which can be determined by turning the equipment off and on, the user is encouraged to try to correct the interference by one of more of the following measures:

- Reorient or relocate the receiving antenna.
- Increase the separation between the equipment and the receiver
- Connect the equipment into an outlet on a circuit different from that to which the receiver is connected.
- Consult a dealer or an experienced radio/TV technician for help.



The devices fully comply with norm EN 50081-2 (Emission Test Series) as well as EN 50082-2 (Immunity Test Series).

### 7.4 RoHS and WEEE Statement

The SLG1430 product family complies with requirements of the following directives:

- EU Directive 2002/96/EC on waste electrical and electronic equipment (WEEE), OJ13.02.2003; esp. its Article 6 (1) with Annex II.
- EU Directive 2002/95/EC on the restriction of the use of certain hazardous substances in electrical and electronic equipment (RoHS), OJ 13.02.2003; esp. its Article 4.



## Headquarter and Sales Office

SENSIRION AG  
Laubisruestr. 50  
CH-8712 Staefa ZH  
Switzerland

Phone: +41 44 306 40 00  
Fax: +41 44 306 40 30  
[info@sensirion.com](mailto:info@sensirion.com)  
<http://www.sensirion.com>

SENSIRION Korea Co. Ltd.  
#1414, Anyang Construction Tower B/D,  
1112-1, Bisan-dong, Anyang-city,  
Gyeonggi-Province, South Korea

Phone: +82-31-440-9925~27  
Fax: +82-31-440-9927  
[info@sensirion.co.kr](mailto:info@sensirion.co.kr)  
<http://www.sensirion.co.kr>

SENSIRION Inc.  
Westlake Pl. Ctr. I, suite 204  
2801 Townsgate Road  
Westlake Village, CA 91361  
USA

Phone: +1 805 409 4900  
Fax: +1 805 435 0467  
[michael.karst@sensirion.com](mailto:michael.karst@sensirion.com)  
<http://www.sensirion.com>

SENSIRION China Co. Ltd.  
Room 2411, Main Tower  
Jin Zhong Huan Business Building,  
Futian District, Shenzhen, PR China  
Postal Code 518048

Phone: +86 755 8252 1501  
Fax: +86 755 8252 1580  
[info@sensirion.com.cn](mailto:info@sensirion.com.cn)  
<http://www.sensirion.com.cn>

SENSIRION Japan  
Sensirion Japan Co. Ltd.  
Shinagawa Station Bldg. 7F  
4-23-5 Takanawa  
Minato-ku, Tokyo, Japan

Phone: +81 3-3444-4940  
Fax: +81 3-3444-4939  
[info@sensirion.co.jp](mailto:info@sensirion.co.jp)  
<http://www.sensirion.co.jp>

Find your local representative at: <http://www.sensirion.com/reps>