

Model Pico Plus

Syringe Pump

User's Manual

Pump 11 Pico Plus MA1 70-2213

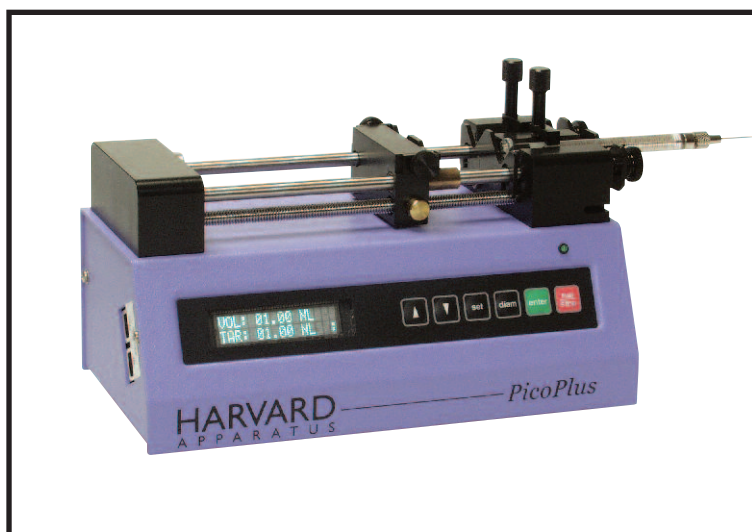

HARVARD

A P P A R A T U S

WEEE/RoHS Compliance Statement

EU Directives WEEE and RoHS

To Our Valued Customers:

We are committed to being a good corporate citizen. As part of that commitment, we strive to maintain an environmentally conscious manufacturing operation. The European Union (EU) has enacted two Directives, the first on product recycling (Waste Electrical and Electronic Equipment, WEEE) and the second limiting the use of certain substances (Restriction on the use of Hazardous Substances, RoHS). Over time, these Directives will be implemented in the national laws of each EU Member State.

Once the final national regulations have been put into place, recycling will be offered for our products which are within the scope of the WEEE Directive. Products falling under the scope of the WEEE Directive available for sale after August 13, 2005 will be identified with a "wheelie bin" symbol.

Two Categories of products covered by the WEEE Directive are currently exempt from the RoHS Directive - Category 8, medical devices (with the exception of implanted or infected products) and Category 9, monitoring and control instruments. Most of our products fall into either Category 8 or 9 and are currently exempt from the RoHS Directive. We will continue to monitor the application of the RoHS Directive to its products and will comply with any changes as they apply.

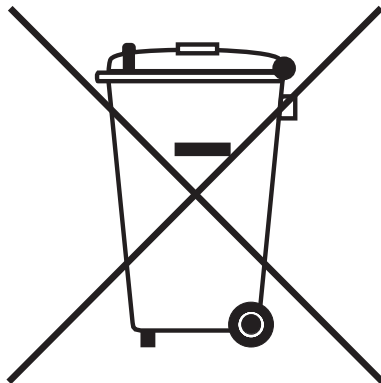

- **Do Not Dispose Product with Municipal Waste**
 - **Special Collection/Disposal Required**

Table of Contents

1

SUBJECT	PAGE NO.
General Information - Warranty and Repairs	2
General Safety Summary	3-4
Introduction:	
Theory of Operation	5
Features	5
Front and Rear Views	6
Installation:	
Initial Setup & Location Requirements	7
Loading the Syringe	7
Operation:	
Getting Started:	
<i>Turn Pump ON</i>	8
<i>Function Keys and Run Indicator</i>	8
<i>Entering Syringe Size</i>	9
<i>Entering Flow Rate Range</i>	9
<i>Entering Flow Rate</i>	9
<i>Press Run/Footswitch</i>	9
<i>Check Syringe</i>	9
Advanced Features:	
<i>Volume Mode</i>	10
<i>Power Failure</i>	10
<i>Changing Rates</i>	11
<i>Maintenance</i>	11
<i>Protecting Small, Fragile Syringes</i>	11
Appendices:	
A. Specifications	12
B. Table of Popular Syringe Diameters	13
C. Table of Minimum and Maximum Flow Rates	14
D. Serial Communication	16-19
E. RS232 Connections	20
F. PC Connection	20

General Information

Serial Number

All inquiries concerning our product should refer to the serial number of the unit. Serial numbers are located on the rear of the chassis.

Calibration

All syringe pumps are designed and manufactured to meet their performance specifications at all rated voltages and frequencies. A calibration certificate is available upon request. Contact customer service for details and pricing.

Warranty

Harvard Apparatus warrants this instrument for a period of two year from date of purchase. At its option, Harvard Apparatus will repair or replace the unit if it is found to be defective as to workmanship or material.

This warranty does not extend to damage resulting from misuse, neglect or abuse, normal wear and tear, or accident.

This warranty extends only to the original customer purchaser.

IN NO EVENT SHALL HARVARD APPARATUS BE LIABLE FOR INCIDENTAL OR CONSEQUENTIAL DAMAGES. Some states do not allow exclusion or limitation of incidental or consequential damages so the above limitation or exclusion may not apply to you. **THERE ARE NO IMPLIED WARRANTIES OF MERCHANTABILITY, OR FITNESS FOR A PARTICULAR USE, OR OF ANY OTHER NATURE.** Some states do not allow this limitation on an implied warranty, so the above limitation may not apply to you.

If a defect arises within the two-year warranty period, promptly contact your local distributor or Harvard Apparatus, 84 October Hill Road Holliston, Massachusetts 01746-1388 using our toll free number 1-800-272-2775 (valid only in the U.S., outside U.S. call 508-893-8999). Goods will not be accepted for return unless an RMA (returned materials authorization) number has been issued by our customer service department. The customer is responsible for shipping charges. Please allow a reasonable period of time for completion of repairs, replacement and return. If the unit is replaced, the replacement unit is covered only for the remainder of the original warranty period dating from the purchase of the original device.

This warranty gives you specific rights, and you may also have other rights which vary from state to state.

Repair Facilities and Parts

Harvard Apparatus stocks replacement and repair parts. When ordering, please describe parts as completely as possible, preferably using our part numbers. If practical, enclose a sample or drawing. We offer a complete reconditioning service.

CAUTION
FOR RESEARCH USE ONLY
NOT FOR CLINICAL
USE ON PATIENTS

CAUTION

This pump is not registered with the FDA and is not for clinical use on human or veterinary patients. It is intended for research use only.

General Safety Summary

Please read the following safety precautions to ensure proper use of your syringe pump. To avoid potential hazards and product damage, use this product only as instructed in this manual. If the equipment is used in a manner not specified by the manufacturer, the protection provided by the equipment may be impaired.

To Prevent Hazard or Injury:

Use Proper Power Supply

The pump is supplied with an approved power supply and line cord. To maintain the safety integrity of the device, use only one of the following power supplies:

Ault Inc.

Model No.: PW118
Output: 12 Vdc, 1.5 A
Input: 100-250 Vac, 50-60 Hz, .5A

Cui Stack

Model No.: SA06N12-V
Output: 12 Vdc, 2.0 A
Input: 100-240 Vac, 50-60 Hz, .8A

Globtek Inc

Model No.: GT-4201D-12
Output: 12 Vdc, 1.66 A
Input: 100-240 Vac, 50-60 Hz, 0.6A

Use Proper Line Cord

Use only the line cord shipped with the product and make sure line cord is certified for country of use.

Ground the Product

This product is grounded through the return path of the DC power supply. To avoid electric shock, use only approved power supply and line cord with the product.

Make Proper Connections

Make sure all connections are made properly and securely.

Observe all Terminal Ratings

Review the operating manual to learn the ratings on all connections.

General Safety Summary

4

Avoid Exposed Circuitry

Do not touch any electronic circuitry inside of the product.

Do Not Operate with Suspected Failures

If damage is suspected on or to the product do not operate the product. Contact qualified service personnel to perform inspection.

Observe all Warning Labels on Product

Read all labels on product to ensure proper usage.



CAUTION
Refer to Manual



*Functional Ground
Terminal*

Environmental Conditions

Indoor use only

Temperature 4°C to 40°C (40°F to 104°F)

Humidity 20% to 80% RH (non-condensing)

Well Ventilated Room

Altitude up to 2000 m

Mains Voltage Fluctuation not to Exceed +/- 10% of Nominal

Transient Over Voltage, Category II

Pump is Rated Pollution Degree 2 in Accordance with IEC 664

Introduction

Theory of Operation:

The pico plus is designed as a low cost infusion pump capable of delivering very low flow rates at low to moderate back pressures.

The pump can hold two syringes of any make from 0.5 μ l to 10ml. The diameter of the syringes is entered via the keypad and the internal microprocessor drives a precision stepper motor to produce accurate fluid flow.

Non-volatile memory stores the last syringe diameter and flow rate along with other configuration data.

The “Power Failure Mode” can be set to either turn the pump off in the event of power failure or to resume pumping when power resumes.

Features:

Bright Display and Easy-To-Use Interface

A new, two-line 16 character display along with six membrane keys make this a most attractive but powerful, easy-to-use syringe pump. Only two entries are required to start pumping; syringe Inside Diameter (mm) and pumping flow rates. The Flow rate can be changed while the Pump is running. Direct enter flowrates in ml, μ l, nl, and pl.

Two Modes of Operation, Constant Flow Rate and Volume Dispense

The pico plus will operate continuously in RATE mode or accurately dispense a specific amount of fluid in VOLUME mode. All modes can be operated from keypad, footswitch (included) or external controller via serial connection (included). Withdraw mode makes it easy to “load” capillaries, pipettes and syringes. Adjustable end of travel limit stop to protect small syringes.

Smooth Flow

Enhanced micro-stepping pump profiles deliver very smooth and consistent flow, that is virtually pulse free.

Nonvolatile Memory

The pump remembers its last syringe size, flow rate used and configuration settings.

Power Fail Mode

In a power failure the Pump can either RESUME or STOP pumping when power is returned.

CE Mark Approved—UL+CSA (ETL)

The pico plus meets all relevant European EMC and Safety requirements for laboratory equipment.

Pico Front and Rear Views

6

Harvard Apparatus Pico Plus Syringe Pump

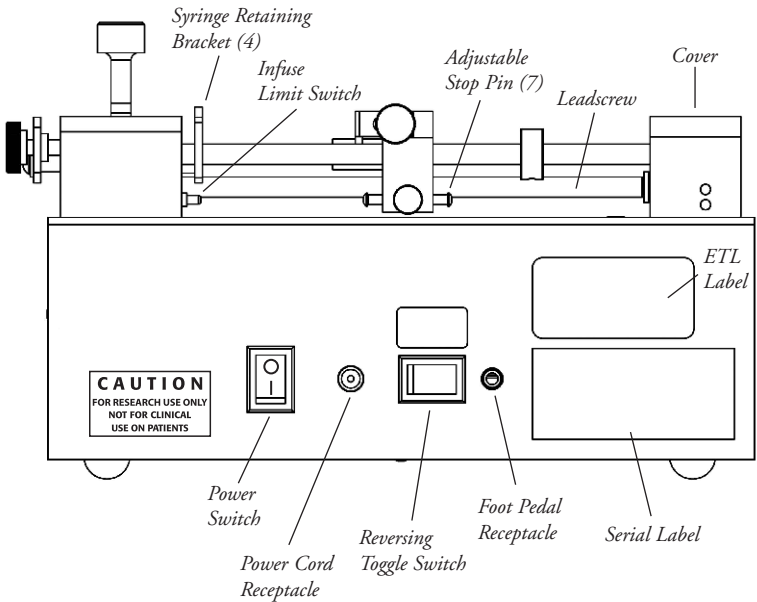
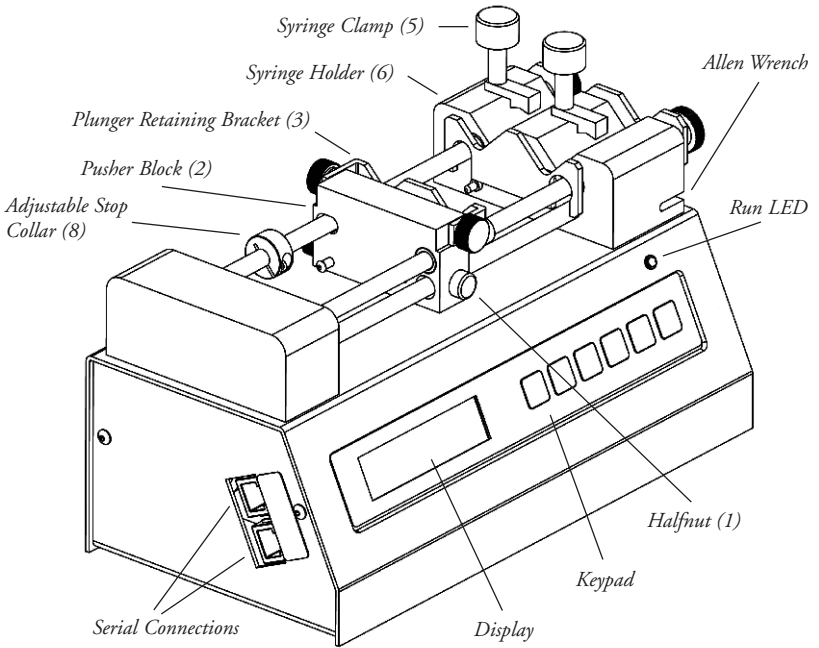

Installation

7

Initial Set-up

1. Read the manual to become familiar with all features and functions of the pico plus.
2. Connect the external DC power supply and line cord to the pump and main supply.
3. Turn on main power switch located on the rear panel. The display will now illuminate indicating that the power connections are correct. The display will indicate POWER FAIL. (this is normal as the pump indicates on the display if power was disrupted since last use.)

Location Requirements for the Syringe Pump

- A sturdy, level, clean and dry surface
- Minimum of one inch (2cm) clearance around the pump
- Appropriate environmental conditions
- A well ventilated room

Loading the Syringe

1. Press the bronze halfnut button (1) on the side of the pusher block to release it from the leadscrew.
2. While holding the button 'in', slide the pusher block (2) to the left.
3. Loosen plunger retaining bracket (3) and syringe retaining bracket (4) by slightly unscrewing the cap screws.
4. Loosen the thumbscrew on the syringe clamps (5) and rotate the clamp out of the way.
5. Lay the syringe into the V-shaped slots on the syringe holder block (6).
6. Swing the syringe clamps (5) over the syringes and tighten the thumbscrews to secure the syringe in place.
7. Slide the syringe retaining bracket (4) up to secure the flange on the syringe barrel against the syringe holder block.
8. Press the halfnut button (1) and hold it in while sliding the pusher block up to the syringe plunger.
9. Tighten the thumbscrews on the plunger retaining bracket (3).
10. The infuse limit switch is adjusted by loosening the thumbscrew on the back of the pusher block and sliding the stop pin (7) in or out to the desired location [to protect the syringe from bottoming out].
11. The withdraw limit switch [enclosed in the cover] is adjusted by securing the stop collar (8) into the desired position.

Operation: Getting Started

Getting started

1. Turn Pump 'ON'

Turn on power using the switch on rear of the pump, the display will light, and indicate POWER FAIL. (this is normal as the pump indicates on the display if power was disrupted since last use.)

2. Function Keys and Run Indicator

Refer to the colored keypad at the front of the pump to identify the following functions starting from the right.



RUN/STOP – This turns the pump motor on and off (also accomplished by pressing the foot switch).

ENTER – This key enters the data that is on the display into the memory of the pump. Also used to query the flow rate.

DIAM – Used to enter or query the syringe diameter.

SET – This key is used to select which digit of the display is to be changed, to move the decimal point and to move between modes. Each time the set key is pressed the underline cursor below the digit or character on the display moves one step to the right. It is used in conjunction with the ascending and descending keys. When it the display shows the desired the correct value the set key will advance right to the next digit.

△▽ – The ascending and descending keys are used to change the numbers on the display. △ Up key makes numbers increase, ▽ Down Key makes numbers decrease. When the underline cursor is placed below the decimal point, the △▽ keys shift the decimal one place up or down.

Run Indicator – When the pump is running, the highly visible, green LED above the RUN/STOP key will illuminate.

3. Enter Syringe Size

Enter the inside diameter (ID) of the syringe you wish to use. Units are in millimeters (mm).

If you do not know your syringe diameter, refer to appendix B for nominal inside diameters of most popular syringes. For the greatest accuracy or if your syringe is not listed in appendix B, measure the inside diameter with a vernier caliper or other precision measuring tool. Record this value for future use.

Operation: Getting Started

Press SET followed by the DIAM key. The previously used diameter will appear on the display. The underline cursor will appear under the left-most digit or decimal point. The Δ and ∇ keys are used to scroll to the desired number and the SET key moves the underline cursor one place to the right. Once the desired diameter is displayed, press the ENTER key to place this value into memory.

4. *Enter Flow Rate Range*

Choose your flow rate units; picoliters, nanoliters, microliters or milliliters; per minute or per hour.

From the initial RATE VOL CONFIG menu, using the Δ or ∇ key, move the underline cursor under the CONFIG mode menu prompt. Press the SET key to enter the CONFIG mode. Press the SET key again to move the underline cursor to the flow rate choices. Choose your flow rate units while in the SET:UNITS mode by pressing the Δ or ∇ keys to scroll the four flow rate choices; ml/min, μ l/min, ml/hr, μ l/hr. Once the desired flow rate units are displayed, press the ENTER key to return to the main SET:CONFIG mode. Press SET or ENTER again to put your desired flow rate units into memory and return to the RATE VOL CONFIG menu.

5. *Enter Flow Rate*

From the initial RATE VOL CONFIG menu, press the SET key to enter the SET:RATE mode. Each time you change the syringe diameter, the previously used flow rate is erased. If the syringe diameter is unchanged, the previously used flow rate will appear on the display. The underline cursor will appear under the left-most digit or decimal point. The Δ and ∇ keys are used to scroll to the desired number and the SET key moves the underline cursor one place to the right. Once the desired rate is displayed, press the ENTER key to place this value into memory.

6. *Press RUN Or Foot Switch*

Press the RUN/STOP key or press the foot switch to start pump and begin pumping. The Run Indicator (Green LED above the RUN/STOP key) will light when the pump is on and pumping.

7. *Check Syringe Often*

The pico plus pump will shut itself off when the syringe is empty via the infuse limit switch. If the switch is improperly set or the syringe is overloaded, the pump will not shut itself off. Although this presents no hazard to the user or the pump, it is prudent to check the syringe from time to time.

Operation: Advanced Features

1. Volume Mode

The pico plus can be set to dispense a precise volume and then stop. To activate the volume dispense mode a target volume must be set.

To set a target volume, at the RATE VOL CONFIG display, move the underline cursor, using the Δ or ∇ key, to VOL. Press the SET key to enter the VOL set mode. Use the Δ or ∇ key and the SET key to display a target volume from 00.01 to 99.99. Volume units are pl (picoliters), nl (nanoliters), ml (milliliters) or μ l (microliters). Target volume units are established in the CONFIG SET:UNITS mode; example: if your pumping units are ml/ min or ml/ hr, then the volume dispense units will be ml's. Press the ENTER key to select the desired target volume. Exit the VOL mode by pressing the ENTER key.

Once you press the RUN key, the pump will run until the target volume is delivered. The display will show the actual volume dispensed along with the target volume. Press the RUN key each time you want to repeat the volume dispense. If you press the STOP key during a volume dispense, you can restart the pump at the place you stopped by pressing the RUN key again.

To exit the volume dispense mode, set the target volume to 00.00 or turn off and on the pump via the main power switch. NOTE: In the event of a power failure, the actual dispensed volume and the target volume are not retained in memory. This means that while in volume dispense mode, if a power failure occurred, the pump would not resume volume dispense pumping even if the POWER ON mode was set to run.

2. Power Failure

In the event of a momentary or prolonged power failure, the pico plus can be set to either;

- a) Resume pumping when power is returned, with "POWER FAIL" on the display.
- b) Not start pumping when power is returned, with "POWER FAIL" on the display.

To set the power fail mode, at the RATE VOL CONFIG display, move the underline cursor, using the Δ or ∇ key, to CONFIG. Press the SET key to enter the CONFIG mode options. Use the Δ or ∇ key to scroll the CONFIG options until you reach the SET:POWER ON: display. Press the SET key again moving the underline cursor to the right. Use the Δ or ∇ key to scroll the POWER:ON choices; 'stop' or 'run'. Press the ENTER key to select either mode. Exit the CONFIG mode by pressing the ENTER key again and save the POWER:ON setting in memory.

Operation: Advanced Features

3. *Display Intensity*

For varying light conditions, four levels of intensity can be set on the vacuum fluorescent display

To set the desired display intensity, at the RATE VOL CONFIG display, move the underline cursor, using the Δ or ∇ key, to CONFIG. Press the SET key to enter the CONFIG mode options. Use the Δ or ∇ key to scroll the CONFIG options until you reach the SET:INTENSITY:. Press the SET key again moving the underline cursor to the right. Use the Δ or ∇ key to scroll the SET : INTENSITY choices; "1", "2", "3", "4" (4 is highest intensity, 1 is the lowest intensity). Press the ENTER key to select the desired display intensity. Exit the CONFIG mode by pressing the ENTER key again and save the INTENSITY setting in memory.

4. *Changing Rates*

If the pump is running at an existing rate it will continue to do so until a new rate is entered. Except for volume mode, the flow rate can be changed while the pump is running. As soon as the ENTER key is pressed the pump will change to the new flow rate. To change rates from the keypad, while in volume mode, the pump must be stopped first. The pump must be stopped to change the flow rate range (units) while in either mode.

5. *Reversing the Flow Direction*

The pump is equipped with a reversing switch to toggle from infuse to withdraw. The flow rate will be the same for both infuse and withdraw modes unless changed manually (refer to #4).

CAUTION: Remember to check the switch before pressing run to ensure it is indicating the desired direction.

6. *Maintenance*

Keep the pump clean and dry. Avoid liquid spills that may find their way into the electronics.

A small container of grease is provided for periodic lubrication of the lead screw and guide rods. It is important to keep these guide rods clean and lubricated.

To clean the exterior surfaces, use a lint-free cloth to remove loose dust. Use care to avoid scratching the display window. For more efficient cleaning, use a soft cloth dampened with water or an aqueous solution of 75% isopropyl alcohol.

If the pump does not work properly, contact Harvard Apparatus for appropriate instructions.

7. *Protecting Small, Fragile Syringes*

The pico plus will hold microliter size syringes down to 0.5 μl size. These small syringes have fine wire plungers that may be damaged if allowed to bottom out. Be sure to set the limit switches properly to prevent damage to small syringes.

Appendix A

12

Pico Plus VPF Specifications

Type	Microprocessor dual syringe, infuse/withdraw
Syringe/Size for Pico Plus with Holder For:	Plastic or glass
2 Syringes	From 0.5 µl to 10 ml
Flow Rate Range:	
Minimum / Maximum	1.3 pl/min with 0.5 µl syringe 0.4393 ml/min with 10 ml syringe 0.8788 ml/min using 2 x 10 ml syringes (combined output)*
Calibration	Automatic, enter syringe size up to 16 mm Inside Diameter
Display	2 line, 16 character vacuum fluorescent display and green run led
Nonvolatile Memory	Stores diameter, rate and configuration settings
Maximum Force	(25 lb.) **
Maximum Pressure	100 p.s.i. with 10 cc syringe; 175 p.s.i. with 1 ml syringe
Drive Motor	1.8° step angle geared 36:1 motor
Step Rate:	
Minimum / Maximum	1 pulse in 27.6 sec / 200 steps/sec
Pusher Advance/Step	0.0444 µm pusher advance per motor step
Pusher Travel Rate:	
Minimum / Maximum	0.0388 µm/min / 0.8333 mm/min
Dynamic Range	1 to 16,384
Leakage to Ground	Typically < 150 µA
Ground Resistance	Typically < 0.05 ohms
Input Power	12 VDC 1.5 Amps
Input Power Connection	2.5mm ID x 5.5 mm OD male plug
Power Supply	100/250 VAC, 50/60 Hz, 18 Watts External Universal Power Supply, Use Only a Harvard Apparatus Approved Power Supply and Line Cord
Size, H x W x D	11.4 x 22.9 x 11.4 cm (4-1/2 x 9 x 4-1/2 in)
Weight	2.3 kg (5 lb)

* Additional accessories are required to achieve this flow rate.

** Actual force is higher, but not recommended for applications requiring more than 25 lbs of force.

Appendix B: Syringe Inside Diameter

<i>Terumo</i>		<i>Stainless Steel</i>		<i>GE</i>	
<u>Size</u>	<u>Diameter</u>	<u>Size</u>	<u>Diameter</u>	<i>Scientific Glass</i>	
3 cc	8.95 mm	8 cc	9.525 mm	<i>Engineering</i>	
5	13.00			<u>Size</u>	<u>Diameter</u>
10	15.80	<i>Becton Dickinson</i>		25 µl	0.73 mm
1 cc	4.78 mm	<i>Plastic "Plasticpak"</i>		50	1.03
		<u>Size</u>	<u>Diameter</u>	100	1.46
		1 cc	4.78 mm	250	2.30
		3	8.66	500	3.26
		5	12.06	1.0 ml	4.61 mm
		10	14.50	2.5	7.28
		<i>Air-Tite "All Plastic"</i>		5	10.30
		<u>Size</u>	<u>Diameter</u>	10	14.57
		2.5 cc	9.60 mm	<i>Hamilton-Microliter</i>	
		5.0	12.45	<i>Series Gastight</i>	
		10	15.90	<u>Size</u>	<u>Diameter</u>
		<i>Unimetrics</i>		.5 µl	0.103 mm
		<i>Series 4000 & 5000</i>		1	0.1457
		<u>Size</u>	<u>Diameter</u>	2	0.206
		10 µl	0.460 mm	5	0.3257
		25	0.729	10	0.460
		50	1.031	25	0.729
		100	1.460	50	1.031
		250	2.300	100	1.46
		500	3.260	250	2.3
		1000	4.610	500	3.26
				1.0 ml	4.61 mm
				2.5	7.28
				5	10.3
				10	14.57

Cadence Science, Inc.
Formerly Popper & Sons, Inc.

"Perfektum" Glass

<u>Size</u>	<u>Diameter</u>
0.25 cc	3.45 mm
0.5	3.45
1	4.50
2	8.92
3	8.99
5	11.70
10	14.70

Appendix C: Flow Rates

Syringe	ID (mm)	pL/hr		pL/min		nL/hr		nL/min	
		min	max	min	max	min	max	min	max
Min	0.1	77.78	9999	1.296	9999	0.0778	1241	0.0013	20.69
1ul	0.15	172.2		2.870		0.1722	2794	0.0029	46.57
2ul	0.21	338.9		5.648		0.3389	5477	0.0056	91.28
5ul	0.33	827.8		13.80		0.8278	9999	0.0138	225.4
10ul	0.46	1606		26.76		1.606		0.0268	437.9
25ul	0.73	4044		67.41		4.044		0.0674	1103
50ul	1.03	8043		134.1		8.043		0.1341	2196
100ul	1.46			269.4		16.16		0.2694	4412
250ul	2.3			668.4		40.11		0.6684	9999
500ul	3.26			1344		80.61		1.344	
1ml/1000µl	4.61			2686		161.2		2.686	0.1612
2.5ml	7.28			6696		401.8		6.697	
3ml	8.66			9481		568.9		9.482	
5ml	10.3					805.6		13.43	
10ml	14.57					1610		26.83	

A table of minimum and maximum diameter values

pL/hr max diameter: 1.14

pL/mn max diameter: 8.89

mL/mn min diameter: 0.22

Appendix C: Flow Rates

ul/hr min	max	ul/min min	max	ml/hr min	max	ml/min min	max
0.0001	1.241				0.0011		
0.0003	2.794				0.0027		
0.0004	5.477				0.0054		
0.0009	13.52		0.2254		0.0135		0.0002
0.0017	26.28		0.4379		0.0262		0.0004
0.0041	66.17	0.0001	1.103		0.0661		0.0011
0.0081	131.7	0.0002	2.196		0.1317		0.0021
0.0162	264.7	0.0003	4.412		0.2647		0.0044
0.0402	656.7	0.0007	10.94		0.6567		0.0109
0.0806	1317	0.0014	21.94	0.0001	1.317		0.0219
2637	0.0027	43.94	0.0002	2.637		0.0439	
0.4018	6580	0.0067	109.7	0.0005	6.580		0.1097
0.5689	9313	0.0095	155.2	0.0006	9.313		0.1552
0.8056	9999	0.0135	219.6	0.0009	13.16	0.0001	0.2196
1.610		0.0269	439.4	0.0017	26.36	0.0002	0.4393

Serial connector (RJ-11 style) pinning:

<u>Position*</u>	<u>Signal</u>
1	GND
2	GND
3	TxD
4	RxD

• *The connector position as viewed looking into the RJ-11 connector reading left to right*

Baud rate and address

The baud rate and address are set in the CONFIG mode, options are described as follows:

a. Pump Address

To set the pump address, at the RATE VOL CONFIG display, move the underline cursor, using the ▼ or ▲ key, to CONFIG. Press the SET key to enter the CONFIG mode options. Use the ▼ or ▲ to scroll the CONFIG options until you reach the SET:ADDRESS. Press the SET key again moving the underline cursor to the right. Use the ▼ or ▲ to scroll the two digit number fields. Use the ▼ or ▲ key and the SET key to display a unique pump address from 00 to 99. Press the ENTER key to select the desired pump address. Exit the CONFIG mode by pressing the ENTER key again and save the ADDRESS setting in memory.

b. Baud Rate

To set the pump address, at the RATE VOL CONFIG display, move the underline cursor, using the ▼ or ▲ key, to CONFIG. Press the SET key to enter the CONFIG mode options. Use the ▼ or ▲ key to scroll the CONFIG options until you reach the SET:BAUD. Press the SET key again moving the underline cursor to the right. Use the ▼ or ▲ key to scroll the SET:BAUD choices; '300', '1200', '2400' or '9600'. Press the ENTER key to select the desired baud rate. exit the CONFIG mode by pressing the ENTER key again and save the BAUD setting in memory.

Appendix D: Serial Communication

Operation with Serial control and external Run/Stop switch (foot switch)

<u>Mode</u>	<u>Function</u>	<u>Operation</u>
Local-Keyboard	Run/Stop	Momentary switch contact If pressed when stopped starts pump motor (Run LED lights when running) If pressed when running, stops pump motor
Remote-Serial control		REMOTE mode initiates when pump receives a CR character (ASCII 13) REMOTE is displayed on pump display while in remote mode
	Run	RUN Commands the pump motor to start
	Stop	STP Commands the pump motor to stop
	Exit Remote	KEY Commands the pump to exit REMOTE mode Keyboard Run/Stop key while in REMOTE mode; will stop pump motor if running Will not restart pump motor in REMOTE mode While in REMOTE mode, External Run/Stop connection is ignored

Appendix D: Serial Communication

Commands, Queries and Responses

After each transmission to the pump terminating with a CR character (ASCII 13), the pump enters remote mode and responds with the three character sequence:

CR LF ***prompt***

The prompt character indicates the status of the pump as follows:

<u>prompt</u>	<u>meaning</u>	<u>ASCII code</u>
:	When stopped	(ASCII 58 decimal)
>	When running forward	(ASCII 62 decimal)
*	When stalled	(ASCII 42 decimal)

Pump 11 does not include stall detection

Serial commands and their meanings:

Commands:

KEY	Return to keyboard control. Exit remote mode
RUN	Start infuse (forward direction)
STP	Stop motor
CLV	Clears volume accumulator to zero
CLT	Clears target volume to zero, dispense disabled
REV	Start (Reverse Direction)

Commands with numbers:

MMD	number	Set syringe diameter, units are mm. Rate is set to zero after MMD command.
PLM	number	Set flow rate and range, units are Picoliters per minute
NLM	number	Set flow rate and range, units are Nanoliters per minute
ULM	number	Set flow rate and range, units are microliters per minute
MLM	number	Set flow rate and range, units are milliliters per minute
PLH	number	Set flow rate and range, units are Picoliters per hour
NLH	number	Set flow rate and range, units are Nanoliters per hour
ULH	number	Set flow rate and range, units are microliters per hour
MLH	number	Set flow rate and range, units are milliliters per hour
TGT	number	Set target infusion or refill volume, units are set in the flow rate range choosen

Numbers can be between 0 and 1999.

Leading zeros and trailing decimal point are optional. Any number of digits to the right of the decimal point may be transmitted. The number will be rounded.

Appendix D: Serial Communication

Queries:

DIA	Returns diameter value units in mm
RAT	Returns rate value set in current range units
VOL	Returns current accumulated infused volume, units in ml or μ l depending on range
VER	Returns model and version number of firmware
TAR	Returns target volume, units in ml or μ l depending on range

value format: nnnn.nnn

The returned value is an 8 character string with leading zeros converted to SP characters (ASCII 32 decimal). The fifth character is a decimal point (ASCII 46 decimal)

Queries with string response:

RNG	Returns range message (character string either: ML/HR, ML/MN, UL/HR, UL/MN, NL/HR, NL/MN, PL/HR and PL/MN)
------------	--

Error responses:

CR LF ? CR LF prompt	Unrecognized command
CR LF OOR CR LF prompt	Entered value in out of range

Remote Communication Set-up:

The pico plus is equipped at the factory for remote communications.

The communication format is:

Baud Rate:	User settable 300, 1200, 2400, 9600
Parity:	None
Stop Bits:	2
Data Bits:	8
Duplex:	Half
Address:	User settable 00 (default) to 99

Appendix E: Dual RS-232

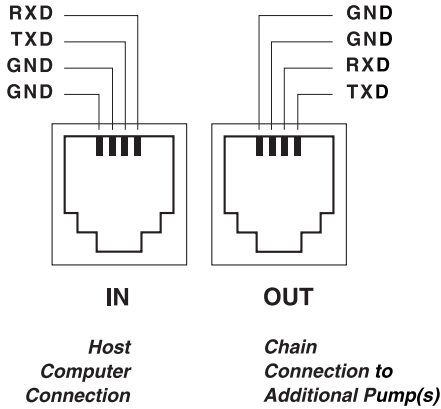

Daisy-Chain Connector & Cables

Part No.	Description
70-2022	RS232 serial cable, 6 ft long, 9 pin d-sub on one end, and RJ11 on the other end
72-2478	Daisy Chain Cable, 6 ft
55-7760	Daisy Chain Cable, 2 ft
72-8340	USB to Serial Adapter

Appendix F: PC Connection

Model '11' Plus Syringe Pump

RJ11 Cable "Straight Thru" Pinning
Max Distance: 15M

DB9 Female to 4/6 PIN RJ11/12 such as L-COM P/N RBA098F

"Computer"

Computer Terminal Port Settings

Baud Rate: 9600
(or match pump baud rate)

Data Bits: 8

Stop Bits: 2

RJ12 - 6 x 6

RJ11 - 6 x 4

View of Cable

Connection Chart

RJ11/RJ12	-	DB9
5	-	3
4	-	2
3	-	5

Front View

STD DB9

2 - RD
3 - TD
5 - Sig ground

View of Adapter

REC
XMIT
GND

Declaration of Conformity

Application of
Council Directive(s): *73/23/EEC, 89/336/EEC*

Standard(s) to which
conformity is declared: *EN61010-1 (1993) + A2 (1995),
EN 61326: 1997 + A1: 1998
Class A Emissions, Class B Immunity*

Manufacturer's Name: *Harvard Apparatus, Inc.*

Manufacturer's Address: *84 October Hill Road
Holliston, Massachusetts 01746
U.S.A.*

Type of Equipment: *Syringe Pump*

Model No.: *70-2213 Pico Plus*

I, the undersigned, hereby declare that the equipment specified above conforms to the above Directive(s) and Standard(s).

Place: *United States of America*

Date: *September 06, 2002*



HARVARD
APPARATUS

Beth Bauman

(Signature)

Beth Bauman

(Full Name)

VP Engineering / Operations

(Position)