

SPECIFICATIONS

PXI-5114

125 MHz, 2-Channel, 8-Bit PXI Oscilloscope

Contents

Definitions.....	2
Conditions.....	2
Vertical.....	3
Analog Input.....	3
Impedance and Coupling.....	3
Voltage Levels.....	3
Accuracy.....	4
Bandwidth and Transient Response.....	4
Spectral Characteristics.....	5
Horizontal.....	6
Sample Clock.....	6
Phase-Locked Loop (PLL) Reference Clock.....	7
External Sample Clock and External Reference Clock In.....	7
Trigger.....	8
Reference (Stop) Trigger.....	8
Programmable Function Interface (PFI 0 and PFI 1).....	11
Waveform.....	11
Calibration.....	12
External Calibration.....	12
Self-Calibration.....	12
Calibration Specifications.....	12
Software.....	13
Driver Software.....	13
Application Software.....	13
Interactive Soft Front Panel and Configuration.....	13
TClk Specifications.....	13
Power.....	14
Physical.....	14
Dimensions and Weight.....	14
Front Panel.....	15
Environment.....	16
Operating Environment.....	16
Storage Environment.....	16

Shock and Vibration.....	16
Compliance and Certifications.....	17
Safety.....	17
Electromagnetic Compatibility.....	17
CE Compliance	17
Online Product Certification.....	18
Environmental Management.....	18

Definitions

Warranted specifications describe the performance of a model under stated operating conditions and are covered by the model warranty.

The following characteristic specifications describe values that are relevant to the use of the model under stated operating conditions but are not covered by the model warranty.

- *Typical* specifications describe the performance met by a majority of models.
- *Nominal* specifications describe an attribute that is based on design, conformance testing, or supplemental testing.

Specifications are *Typical* unless otherwise noted.

Conditions

Specifications are valid under the following conditions unless otherwise noted.

- All filter settings
- All impedance selections
- Sample clock set to 250 MS/s

Warranted specifications are valid under the following conditions unless otherwise noted.

- Temperature range of 0 °C to 55 °C
- The PXI-5114 is warmed up for 15 minutes at ambient temperature
- Self-calibration is completed after warm-up period
- Calibration cycle is maintained
- The PXI/PXI Express chassis fan speed is set to HIGH, the foam fan filters are removed if present, and the empty slots contain PXI chassis slot blockers and filler panels. For more information about cooling, refer to the *Maintain Forced-Air Cooling Note to Users* available at ni.com/manuals.
- External calibration is performed at 23 °C ± 3 °C

Vertical

Analog Input

Number of channels	Two (simultaneously sampled)
Input type	Referenced single-ended
Connectors	BNC

Impedance and Coupling

Input impedance	
50 Ω	50 $\Omega \pm 1.5\%$
1 M Ω	1 M $\Omega \pm 1\%$ in parallel with a typical capacitance of 26 pF
Input coupling	AC ¹ , DC, GND

Voltage Levels

Table 1. Full-Scale (FS) Input Range and Programmable Vertical Offset Range

Input Range (V_{pk-pk})	Vertical Offset Range (V)	
	50 Ω Input	1 M Ω Input
0.04 V	± 0.8	± 0.8
0.1 V		
0.2 V		
0.4 V		
1 V	± 6.5	± 8.0
2 V	± 6.0	
4 V	± 5.0	
10 V	± 2.0	± 30

¹ AC coupling available on 1 M Ω input only.

Table 1. Full-Scale (FS) Input Range and Programmable Vertical Offset Range (Continued)

Input Range (V_{pk-pk})	Vertical Offset Range (V)	
	50 Ω Input	1 M Ω Input
20 V	—	± 25
40 V	—	± 15

Maximum input overload

50 Ω	7 V_{rms} with $ Peaks \leq 10$ V
1 M Ω	$ Peaks \leq 35$ V

Accuracy

Resolution	8 bits
DC accuracy ²	$\pm[(1.5\% \times Reading - Vertical Offset + 2\% \text{ of } Vertical Offset + 0.3\% \text{ of } FS + 200 \mu V)$, warranted
DC drift	$\pm(0.03\% \times Reading + 0.06\% \text{ of } FS + 40 \mu V)$ per $^{\circ}C$
Crosstalk ³	
At 10 MHz input frequency	≤ -60 dB
At 100 MHz input frequency	≤ -45 dB

Bandwidth and Transient Response

Bandwidth (-3 dB)	
0.04 V_{pk-pk} input range	100 MHz, warranted
All other input ranges	125 MHz, warranted
Rise/fall time	
0.04 V_{pk-pk} input range	3.5 ns
All other input ranges	2.8 ns

² Within ± 5 $^{\circ}C$ of self-calibration temperature.

³ CH 0 to/from CH 1, and External Trigger to CH 0 or CH 1

Bandwidth-limiting filter	20 MHz noise filter
AC coupling ⁴ cutoff (-3 dB)	12 Hz
Passband flatness ⁵	±1 dB up to 50 MHz

Figure 1. PXI-5114 Frequency Response, Typical

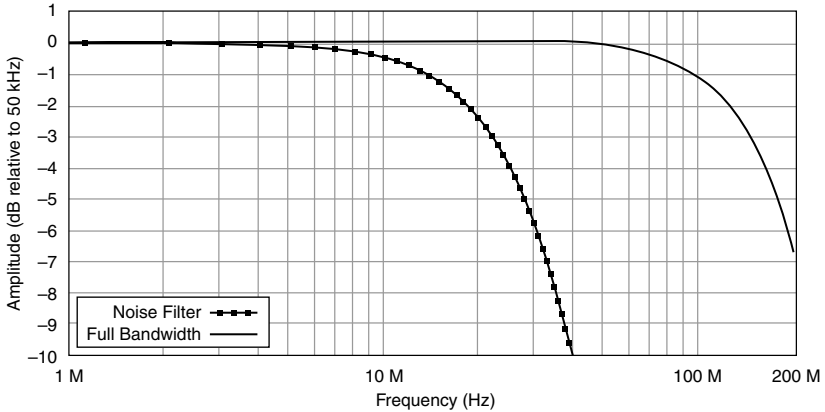

Spectral Characteristics

Spurious-free dynamic range (SFDR) ⁶	58 dBc, typical
Total harmonic distortion (THD) ⁶	-58 dBc, typical
Effective number of bits (ENOB), calculated ⁶	
0.04 V _{pk-pk} input range	6.2
All other input ranges	7.2
Signal to noise and distortion (SINAD) ⁶	
0.04 V _{pk-pk} input range	38 dB
All other input ranges	44 dB

⁴ AC coupling available on 1 MΩ input only.

⁵ Referenced to 50 kHz, with bandwidth-limiting filter disabled.

⁶ 10 MHz, 10 MHz - 1 dBFS input signal. Includes the second through the fifth harmonics. Measured from DC to 125 MHz, with the 20 MHz bandwidth-limiting filter disabled. ENOB values are corrected to full scale.

Noise

Table 2. RMS Noise⁷

Input Range (V_{pk-pk})	Full Bandwidth	20 MHz Filter Enabled
0.04 V	0.45% FS	0.28% FS
All other input ranges	0.28% FS	0.28% FS

Horizontal

Sample Clock

Sources

Internal ⁸	Onboard clock (internal VCXO)
External	CLK IN (front panel SMB connector)

Onboard Clock (Internal VCXO)

Sample rate range

Real-time sampling (single-shot) ⁹	3.815 kS/s to 250 MS/s
Random interleaved sampling (RIS)	250 MS/s to 5 GS/s in 250 MS/s increments

Timebase frequency ¹⁰	250 MHz
----------------------------------	---------

Timebase accuracy

Not phase-locked to Reference clock	±25 ppm
Phase-locked to Reference clock	Equal to the Reference clock accuracy

Sample clock delay range	±1 Sample clock period
--------------------------	------------------------

Sample clock delay resolution	≤20 ps
-------------------------------	--------

⁷ Verified using a 50 Ω terminator connected to input.

⁸ Internal Sample clock is locked to the Reference clock or derived from the onboard VCXO.

⁹ Divide by n sampling used for all rates less than 250 MS/s. For more information about the Sample clock and decimation, refer to the [NI High-Speed Digitizers Help](#).

¹⁰ When not using external Sample clock.

External Sample Clock

Source	CLK IN (front panel SMB connector)
Frequency range ¹¹	50 MHz to 250 MHz
Duty cycle tolerance	45% to 55%

Phase-Locked Loop (PLL) Reference Clock

Sources	PXI_CLK10 (backplane connector) CLK IN (front panel SMB connector)
Frequency range ¹²	1 MHz to 20 MHz in 1 MHz increments Default: 10 MHz
Duty cycle tolerance	45% to 55%
Exported Reference clock destinations	PFI <0..1> (front panel 9-pin mini-circular DIN connector) PXI_Trig <0..7> (backplane connector)

External Sample Clock and External Reference Clock In

Source	CLK IN (front panel SMB connector)
Input voltage range	
Sine wave	0.65 V _{pk-pk} to 2.8 V _{pk-pk} (0 dBm to 13 dBm)
Square wave	0.2 V _{pk-pk} to 2.8 V _{pk-pk}
Maximum input overload	7 V _{rms} with Peaks ≤ 10 V
Impedance	50 Ω
Coupling	AC

¹¹ Divide by n decimation available where $1 \leq n \leq 65,535$. For more information about the Sample clock and decimation, refer to the [NI High-Speed Digitizers Help](#).

¹² The PLL Reference clock frequency must be accurate to ±50 ppm.

Trigger

Reference (Stop) Trigger

Trigger types ¹³	Edge Window Hysteresis Video Digital Immediate Software
Trigger sources	CH 0 CH 1 TRIG PXI_Trig <0..6> PFI <0..1> PXI Star Trigger RTSI <0..6> Software
Time resolution	
Onboard clock, time-to-digital conversion circuit (TDC) on	40 ps
Onboard clock, TDC off	4 ns
External clock, TDC off	External clock period
Minimum rearm time ¹⁴	
TDC on	10 μs
TDC off	2 μs
Holdoff	From rearm time up to $[(2^{35} - 1) \times \text{Sample clock period}]$
Trigger delay	From 0 up to $[(2^{35} - 1) - \text{Posttrigger samples}] \times (1/\text{Sample rate})$, in seconds

¹³ Refer to the following sources and the *NI High-Speed Digitizers Help* for more information about which sources are available for each trigger type.

¹⁴ Holdoff set to 0. Onboard Sample clock at maximum rate.

Analog Trigger

Trigger types	Edge Window Hysteresis
Sources	CH 0 (front panel BNC connector) CH 1 (front panel BNC connector) TRIG (front panel BNC connector)
Trigger level resolution	8 bits (1 in 256)
Trigger level range	
CH 0, CH 1	100% FS
TRIG (external trigger)	±5 V
Edge trigger sensitivity	
CH 0, CH 1	5% FS up to 100 MHz
TRIG (external trigger)	0.5 V _{pk-pk} up to 100 MHz
Level accuracy	
CH 0, CH 1	±5% FS up to 100 MHz
TRIG (external trigger)	±0.5 V up to 10 MHz
Jitter	≤65 pS _{rms}
Trigger filters	
Low frequency (LF) reject	50 kHz
High frequency (HF) reject	50 kHz

Digital Trigger

Trigger type	Digital
Sources	PXI_Trig <0..6> (backplane connector) PFI <0..1> (front panel 9-pin mini-circular DIN connector) PXI Star trigger (backplane connector)

Video Trigger

Trigger type	Video
Sources	CH 0 (front panel BNC connector) CH 1 (front panel BNC connector) TRIG (front panel BNC connector)
Video trigger types	Specific Line Any Line Specific Field
Standards ¹⁵	
SDTV	M-NTSC B/G-PAL SECAM M-PAL
EDTV	480i/59.94 fps 480i/60 fps 480p/59.94 Fps 480p/60 Fps 576i/50 fps 576p/50 Fps
HDTV ¹⁶	720p/50 Fps 720p/59.94 Fps 720p/60 Fps 1080i/50 fps 1080i/59.94 fps 1080i/60 fps 1080p/24 Fps

External Trigger

Connector	TRIG (front panel BNC connector)
Impedance	1 M Ω in parallel with 22 pF
Coupling	AC, DC
AC-coupling cutoff (-3 dB)	12 Hz
Input voltage range	± 5 V
Maximum input overload	$ \text{Peaks} \leq 42$ V

¹⁵ fps = fields per second. Fps = frames per second.

¹⁶ This trigger type does not support negative trigger polarity.

Programmable Function Interface (PFI 0 and PFI 1)

Connector	AUX I/O (front panel 9-pin mini-circular DIN connector)
Direction	Bidirectional
As an Input (Trigger)	
Destinations	Start trigger (acquisition arm) Reference (Stop) trigger Arm reference trigger Advance trigger
Input impedance	150 k Ω
V _{IH}	2.0 V
V _{IL}	0.8 V
Maximum input overload	-0.5 V, 5.5 V
Maximum frequency	25 MHz
As an Output (Event)	
Sources	Start trigger (acquisition arm) Reference (Stop) trigger End of Record Done (end of acquisition) Probe Compensation ¹⁷
Output impedance	50 Ω
Logic type	3.3 V CMOS
Maximum drive current	± 24 mA
Maximum frequency	25 MHz

Waveform

Onboard memory sizes ¹⁸	8 MB per channel (standard) 64 MB per channel (option) 256 MB per channel (option)
Minimum record length	1 sample

¹⁷ 1 kHz, 50% duty cycle square wave, PFI 1 only.

¹⁸ Onboard memory is shared between enabled channels.

Number of pretrigger samples ¹⁹	Zero up to full record length
Number of posttrigger samples ¹⁹	Zero up to full record length
Maximum number of records in onboard memory ²⁰	
8 MB	32,768
64 MB	100,000
256 MB	100,000
Allocated onboard memory per record	$(Record\ length \times 1\ byte/sample) + 240\ bytes$, rounded up to next multiple of 128 bytes (minimum 256 bytes)

Calibration

External Calibration

External calibration calibrates the onboard references used in self-calibration and the external trigger levels. All calibration constants are stored in nonvolatile memory.

Self-Calibration

Self-calibration is done on software command. The calibration corrects for gain, offset, triggering, and timing errors for all input ranges.

Related Information

[For information about when to self-calibrate the device, refer to the NI High-Speed Digitizers Help.](#)

Calibration Specifications

Interval for external calibration	2 years
Warm-up time	15 minutes

¹⁹ Single-record and multirecord acquisitions.

²⁰ You can exceed these numbers if you fetch records while acquiring data. For more information, refer to the [NI High-Speed Digitizers Help](#).

Software

Driver Software

Driver support for this device was first available in NI-SCOPE 2.9.

NI-SCOPE is an IVI-compliant driver that allows you to configure, control, and calibrate the PXI-5114. NI-SCOPE provides application programming interfaces for many development environments.

Application Software

NI-SCOPE provides programming interfaces, documentation, and examples for the following application development environments:

- LabVIEW
- LabWindows™/CVI™
- Measurement Studio
- Microsoft Visual C/C++
- .NET (C# and VB.NET)

Interactive Soft Front Panel and Configuration

The NI-SCOPE Soft Front Panel (SFP) allows interactive control of the PXI-5114.

Interactive control of the PXI-5114 was first available in NI-SCOPE SFP version 14.1. The NI-SCOPE SFP is included on the NI-SCOPE media.

NI Measurement Automation Explorer (MAX) also provides interactive configuration and test tools for the PXI-5114. MAX is included on the NI-SCOPE media.

TClk Specifications

You can use the NI TClk synchronization method and the NI-TClk driver to align the Sample clocks on any number of supported devices, in one or more chassis. For more information about TClk synchronization, refer to the *NI-TClk Synchronization Help*, which is located within the *NI High-Speed Digitizers Help*. For other configurations, including multichassis systems, contact NI Technical Support at ni.com/support.

Intermodule SMC Synchronization Using NI-TClk for Identical Modules

Specifications are valid for modules installed in one NI PXI-1042 chassis. These specifications do not apply to PCI modules. Specifications are valid under the following conditions:

- All parameters are set to identical values for each SMC-based module.
- Sample clock set to 250 MS/s.
- All filters are disabled.



Note Although you can use NI-TClk to synchronize non-identical modules, these specifications apply only to synchronizing identical modules.

Skew ²¹	500 ps, typical
--------------------	-----------------

Average skew after manual adjustment ²²	<20 ps, typical
--	-----------------

Sample clock adjustment resolution	<20 ps, typical
------------------------------------	-----------------

Power

Current draw

+3.3 VDC	840 mA
----------	--------

+5 VDC	1.1 A
--------	-------

+12 VDC	250 mA
---------	--------

-12 VDC	170 mA
---------	--------

Total power	13.32 W
-------------	---------

Physical

Dimensions and Weight

Dimensions	3U, one-slot, PXI/cPCI module 21.6 cm × 2.0 cm × 13.0 cm (8.5 in × 0.8 in × 5.1 in)
------------	---

Weight	455 g (16 oz)
--------	---------------

²¹ Caused by clock and analog path delay differences. No manual adjustment performed.

²² For more information about manual adjustment, refer to the *Synchronization Repeatability Optimization* topic in the *NI-TClk Synchronization Help*.

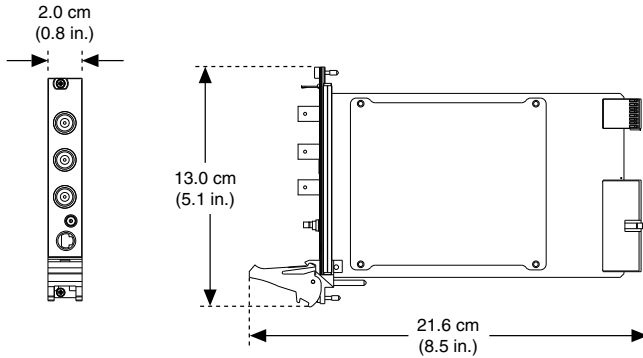
Figure 2. PXI-5114

Front Panel

Table 3. PXI-5114 Front Panel Connectors

Label	Connector Type	Description
CH 0	BNC female	Analog input connection; digitizes data and triggers acquisitions.
CH 1		Analog input connection; digitizes data and triggers acquisitions.
TRIG		External analog trigger; signals on the TRIG connector cannot be digitized.
CLK IN	SMB jack	Imports an external Reference clock or Sample clock to the oscilloscope.
AUX I/O	9-pin mini-circular DIN	PFI 0 and PFI 1 lines for digital trigger input/output and probe compensation.

Table 4. PXI-5114 Front Panel Indicators²³

Label	Description
ACCESS	The ACCESS LED indicates the status of the PCI bus and the interface from the device to the controller.
ACTIVE	The ACTIVE LED indicates the status of the onboard acquisition hardware of the device.

²³ For more information, refer to the [NI High-Speed Digitizers Help](#).

Environment

Maximum altitude	2,000 m (at 25 °C ambient temperature)
Pollution Degree	2

Indoor use only.

Operating Environment

Ambient temperature range	0 °C to 55 °C (Tested in accordance with IEC 60068-2-1 and IEC 60068-2-2.)
Relative humidity range	10% to 90%, noncondensing (Tested in accordance with IEC 60068-2-56.)

Storage Environment

Ambient temperature range	-40 °C to 71 °C (Tested in accordance with IEC 60068-2-1 and IEC 60068-2-2.)
Relative humidity range	5% to 95%, noncondensing (Tested in accordance with IEC 60068-2-56.)

Shock and Vibration

Operational shock	30 g peak, half-sine, 11 ms pulse (Tested in accordance with IEC 60068-2-27. Test profile developed in accordance with MIL-PRF-28800F.)
Random vibration	
Operating	5 Hz to 500 Hz, 0.31 g _{rms} (Tested in accordance with IEC 60068-2-64.)
Nonoperating	5 Hz to 500 Hz, 2.46 g _{rms} (Tested in accordance with IEC 60068-2-64. Test profile exceeds the requirements of MIL-PRF-28800F, Class 3.)

Compliance and Certifications

Safety

This product is designed to meet the requirements of the following electrical equipment safety standards for measurement, control, and laboratory use:

- IEC 61010-1, EN 61010-1
- UL 61010-1, CSA C22.2 No. 61010-1



Note For UL and other safety certifications, refer to the product label or the [Online Product Certification](#) section.

Electromagnetic Compatibility

This product meets the requirements of the following EMC standards for electrical equipment for measurement, control, and laboratory use:

- EN 61326-1 (IEC 61326-1): Class A emissions; Basic immunity
- EN 55011 (CISPR 11): Group 1, Class A emissions
- EN 55022 (CISPR 22): Class A emissions
- EN 55024 (CISPR 24): Immunity
- AS/NZS CISPR 11: Group 1, Class A emissions
- AS/NZS CISPR 22: Class A emissions
- FCC 47 CFR Part 15B: Class A emissions
- ICES-001: Class A emissions



Note In the United States (per FCC 47 CFR), Class A equipment is intended for use in commercial, light-industrial, and heavy-industrial locations. In Europe, Canada, Australia, and New Zealand (per CISPR 11), Class A equipment is intended for use only in heavy-industrial locations.



Note Group 1 equipment (per CISPR 11) is any industrial, scientific, or medical equipment that does not intentionally generate radio frequency energy for the treatment of material or inspection/analysis purposes.



Note For EMC declarations, certifications, and additional information, refer to the [Online Product Certification](#) section.

CE Compliance

This product meets the essential requirements of applicable European Directives, as follows:

- 2014/35/EU; Low-Voltage Directive (safety)
- 2014/30/EU; Electromagnetic Compatibility Directive (EMC)

Online Product Certification

Refer to the product Declaration of Conformity (DoC) for additional regulatory compliance information. To obtain product certifications and the DoC for this product, visit ni.com/certification, search by model number or product line, and click the appropriate link in the Certification column.

Environmental Management

NI is committed to designing and manufacturing products in an environmentally responsible manner. NI recognizes that eliminating certain hazardous substances from our products is beneficial to the environment and to NI customers.

For additional environmental information, refer to the *Minimize Our Environmental Impact* web page at ni.com/environment. This page contains the environmental regulations and directives with which NI complies, as well as other environmental information not included in this document.

Waste Electrical and Electronic Equipment (WEEE)



EU Customers At the end of the product life cycle, all NI products must be disposed of according to local laws and regulations. For more information about how to recycle NI products in your region, visit ni.com/environment/weee.

电子信息产品污染控制管理办法（中国 RoHS）



中国客户 National Instruments 符合中国电子信息产品中限制使用某些有害物质指令 (RoHS)。关于 National Instruments 中国 RoHS 合规性信息，请登录 ni.com/environment/rohs_china。(For information about China RoHS compliance, go to ni.com/environment/rohs_china.)

Information is subject to change without notice. Refer to the *NI Trademarks and Logo Guidelines* at ni.com/trademarks for information on NI trademarks. Other product and company names mentioned herein are trademarks or trade names of their respective companies. For patents covering NI products/technology, refer to the appropriate location: **Help»Patents** in your software, the `patents.txt` file on your media, or the *National Instruments Patent Notice* at ni.com/patents. You can find information about end-user license agreements (EULAs) and third-party legal notices in the `readme` file for your NI product. Refer to the *Export Compliance Information* at ni.com/legal/export-compliance for the NI global trade compliance policy and how to obtain relevant HTS codes, ECCNs, and other import/export data. NI MAKES NO EXPRESS OR IMPLIED WARRANTIES AS TO THE ACCURACY OF THE INFORMATION CONTAINED HEREIN AND SHALL NOT BE LIABLE FOR ANY ERRORS. U.S. Government Customers: The data contained in this manual was developed at private expense and is subject to the applicable limited rights and restricted data rights as set forth in FAR 52.227-14, DFAR 252.227-7014, and DFAR 252.227-7015.

© 2005—2017 National Instruments. All rights reserved.

374179G-01 December 12, 2017